

**V. Voevidko**

Doctor of Engineering Science, Ivano-Frankivsk

National Technical University of Oil and Gas

*The analysis of the window milling was carried out. According to analytical studies were received mathematical formulas that allow determining the deflection on milling tool and dogleg severity of sidetracks in well casing. Recommendations to reduce the hole deviation angle in casing area are given.*

The rational use of drilled hole is a key role in improving the fuel and energy balance of Ukraine. An important reserve for increasing the volumes of oil and gas is inactive, killed and liquidated wells which take a significant share in many deposits of Ukraine. Having analyzed the state of exploitation of main deposits, we can make a conclusion that a great number of obsolete wells may be and should be renewed and put in service to save expenses for new wells drilling.

Today, the technology of sidetrack through milling window in the well casing is the most popular one. The advantages of this technology are: time saving, less volume of metallic sludge, less possibility of accidents during the window milling in the well casing due to use of tools without movable and sliding elements [1-4]. In addition, it is possible to mill the window in the well casing of diameter of up to 168 mm at the depth exceeding 2000 m, as well as in wells which zenith angle is over 5°, and through several well casings [5]. The advantage of this technology is also in possibility of accomplishment of all the works of well reconstruction by rotor system without use of packing machine.

During kickoff and drilling of the additional well bore, the process of formation of hole-like window in well casing is the most important moment. In this case considerable curving forces appear in drill column and it is resulted in problematic passing of this section [6-8]. Some authors state the break of the drill column when it is in the window zone [9, 10]. Besides, there are eventual complications during lowering the well casing and fixation of additional bore. In this case some pressing forces appear because of deformation of pipes in the window, and it will be impossible to lower the well casing in additional bore or its diameter will be deformed [8, 11, 12]. The abovementioned complications and emergency situations are primarily explained by authors by large angle of wedge deflector and as a result small length of window in the well casing, but their evidences are not always justified.

So, we can say the process of window forming in well casing during drilling of additional bores is a complex one, and can be accompanied by accidents; however, there are no detailed studies in this area.

This article is aimed at highlighting the results of theoretical studies of the process of window milling in well casing during drilling of additional bore.

The window milling process in well casing starts when reamer contacts with the well casing, deepens in the wall of the well casing along the AB line till full entering outside limits (Fig. 1)

Then the reamer forms the window of some configuration which depends on geometrical parameters of well casing, reamer and wedge deflector. After completion of window milling, at the final stage, the ditch along CD line is formed; it is located along outer surface of well casing. Then the drilling process continues for several meters for entering the bore in the stable zone of rock near bore [13].

The fig. 1 schematically represents the construction of the conic reamer which is widely used in Russian Federation and other CIS countries during reconstruction of inactive wells by abovementioned method [7].

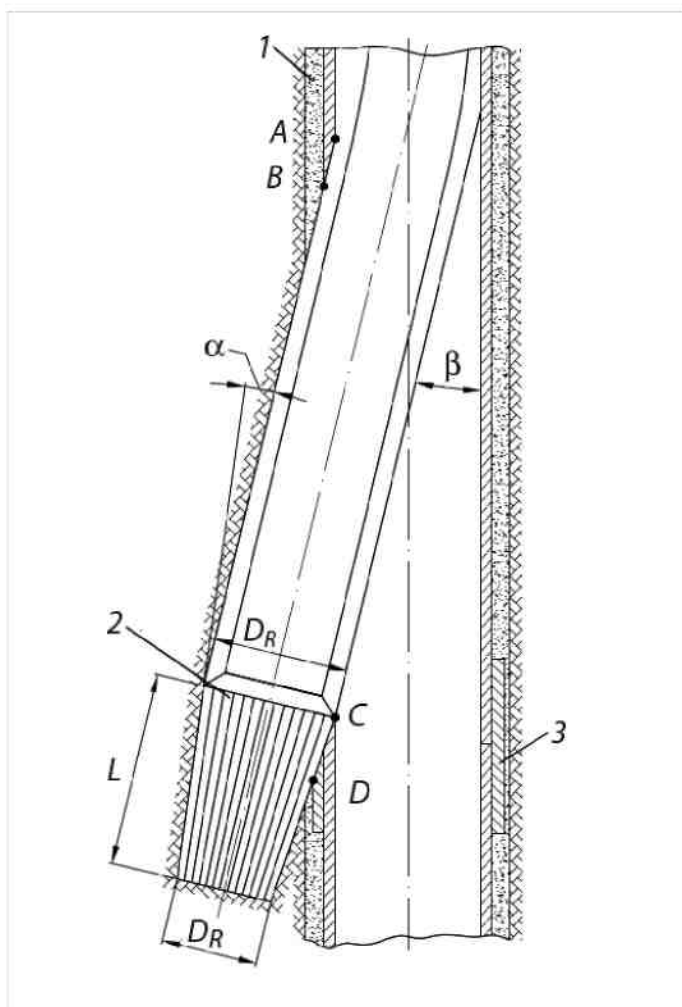

Figure 1. Scheme of window forming in well casing: 1 – well casing; 2- reamer; 3 – coupling;  $\alpha$  – slope angle of lateral surface of reamer to its axle;  $\beta$  – slope angle of wedge deflector; L – length of working part of reamer

At the final stage of window forming in well casing (CD line) the reamer works in heterogeneous environment. On the one side it contacts the well casing and coupling, which mechanic characteristics are higher than rock and cement stone characteristics. It is obviously that in such situation the deflecting force influences the reamer from the well casing (coupling), which will cause its deflection from the straight-line trajectory towards the rocks. The length of contact of reamer with well casing depends on inclination of wedge deflector, depth of the well casing wall and coupling (in case of milling of well casing in the place of coupling location). The length of ditch in well casing (CB line) may be 600-650 mm.

Considering the classical provisions of rock mechanics and operation of rock-destroying tools, we received the following formula for calculation of deflecting force acting from the well casing:

$$F_{\text{вдл}} = \frac{F_{\text{oc}} \left(1 - \frac{r^2}{R^2}\right) \left(1 - \frac{E_{\text{п}}}{E_{\text{м}}}\right) \frac{S_{\text{м}}}{S_{\text{п}}}}{\text{tg}\alpha \cdot \left(\frac{S_{\text{м}}}{S_{\text{п}}} + \frac{E_{\text{п}}}{E_{\text{м}}}\right)}, \quad (1)$$

where  $F_{\text{oc}}$  – axial load on reamer;  $r, R$  – minimum and maximum radii of conic working surface of reamer;  $E_{\text{п}}, E_{\text{м}}$  – modules of rock elasticity and material of well casing;  $S_{\text{м}}, S_{\text{п}}$  – surfaces of parts of lateral surfaces of faces, formed from metal and rock;  $\alpha$  – inclination generating conic surface of reamer to its axle.

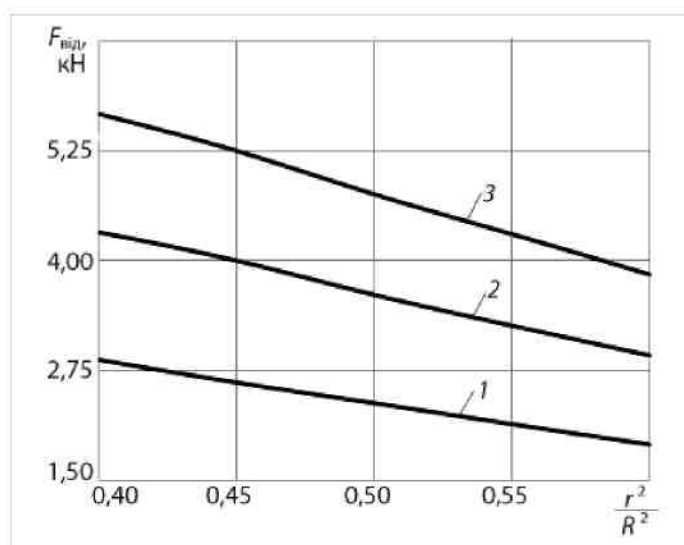

Figure 2. Dependence of deflecting force at reamer on correlation of its radii  $r/R$ : 1, 2, 3 – axial load as per 10, 15 and 20 kN

The equation (1) shows that the value of deflecting force  $F_{\text{вдл}}$  depends from constructive elements of reamer ( $r, R, \alpha$ ), and from degree of environment heterogeneity ( $E_{\text{п}}, E_{\text{м}}, S_{\text{п}}, S_{\text{м}}$ ).

In our case (see Fig. 1) reamer destructs metal of well casing and coupling, cement stone and rock. Modules of elasticity of cement stone and rocks of medium hardness are almost equal, and we consider that the reamer operates in environment rock-metal.

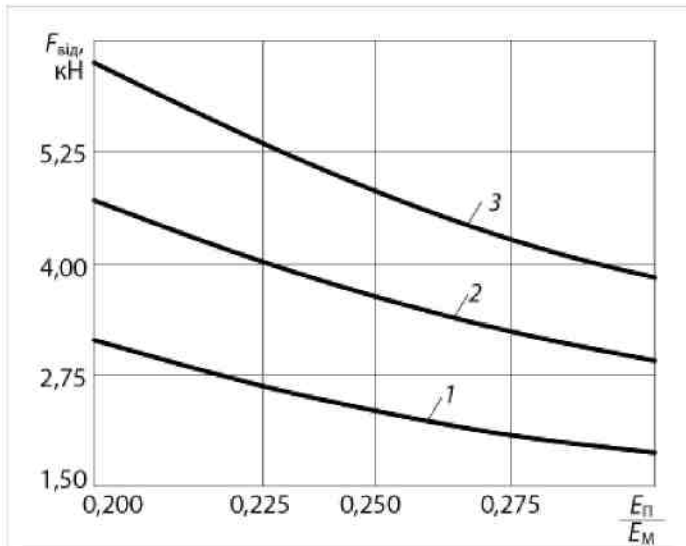

Figure 3. . Dependence of deflecting force on reamer from the correlation of modules of rock elasticity of well casing  $E_{п}/E_{м}$ : 1, 2, 3 – axial load – 10, 15 and 20 kN respectively

Due to the equation (1) we conducted a study to identify the degree of dependence of value  $F_{від}$  on some constructive parameters of reamer and values of environment heterogeneity in case of change of their real values within defined ranges and constructed the appropriate dependencies. We studied the dependence of value  $F_{від}$  on defined parameter(s) on the basis of the average values of others.

The Fig. 2 shows the dependence on the deflection force on reamer of its radii ratio  $r/R$ . The figure shows that at different axial load we obtained a number of lines of approximately the same angle of inclination to the absciss axis. Depending on value of axial load and values  $r/R$  of deflectign forse can change withitn 1,9—5,7 kN.

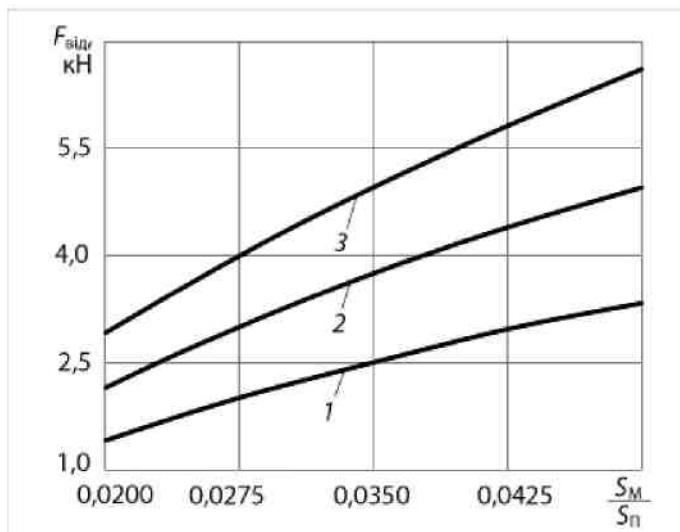

Figure 4. Dependence of deflecting force at reamer on correlation of metal surfaces of well casing and rock  $S_{м}/S_{п}$ : 1, 2, 3 – axial load – 10, 15 and 20 kN respectively

The fig. 3 shows the dependence of deflecting force on reamer on correlation of elasticity modules  $E_{п}/E_{м}$ . Graphic dependences have the form of monotone curves, reflecting a decrease deflecting force on reamer with the increase of the above mentioned correlation, as in this case the difference between the rock elasticity modules and metal decreases. On the basis of the mentioned

graphic dependencies the deflecting force on reamer can change within 1,9—6,2 kN.

The figure 4 shows the dependence of deflecting force on reamer on correlation of metal and rock surfaces SM/SII. The graphic dependencies are curves reflecting growth  $F_m$  with increase of correlation SM/SII. Such increase is logic, as the deflecting force increases with the growth of metal surface of well casing. Depending on value of axial load and values SM/SII the deflecting force may be within 1,5-6,6 kN.

If we know the value of deflecting force on reamer, we can define the intensity of crookedness of well bore as per the formula [14]:

$$\frac{d\alpha}{ds} = \frac{2}{L} \left( \beta_0 + \Theta + K \frac{F_{\text{min}}}{F_{\text{oc}}} \right) \quad (2)$$

where  $L$  – length of directing section from reamer to contact point of loaded drilling pipes with well wall;  $\beta_0$  – angle of misalignment of the bottom of the drill string;  $\Theta$  – turn of reamer axle under applied axial load;  $K$  – coefficient of milling characteristics of rock-destructing tool.

(1) As destructing characteristics of reamer in axial and transverse directions is equal, then  $K = 1$ . Considering (1) the formula (2) will be:

$$\frac{d\alpha}{ds} = \frac{2}{L} \left( \beta_0 + \Theta + \frac{\left(1 - \frac{r^2}{R^2}\right) \left(1 - \frac{E_n}{E_m}\right) \frac{S_m}{S_n}}{\text{tg}\alpha \cdot \left(\frac{S_m}{S_n} + \frac{E_n}{E_m}\right)} \right) \quad (3)$$

The formula elements  $L$  and  $\Theta$  may be found by solving the differential equation of curved axle in the bottom of well casing in inclined well.

The results of calculation of intensity during reamer operation in heterogeneous environment showed that in case of different correlations of parameters of reamer and environment the values may be within 5,7-18,1 grad/m. Considering the inclination of wedge deflector, the density of walls of well casing, as well as possibility of reamer contact with coupling, the general inclination of additional well bore may be within 1,7-8,2 grad. Thus, within the zone of reamer exit from well casing, there may be some local deflections which are probably have a negative influence on the operation of drill string bottom.

These considerable local deflections may negatively be reflected on operation of drilling string bottom.

The developed method of calculation of intensity of incline of drilling string ensures to evaluate properly its values, as well as define the ways of decrease. To reduce the inclination of bore during window milling in casing well, it is necessary to increase the inclination of wedge deflector to necessary value, use spherical or cylinder reamers, as well as conduct milling works between couplings of well casings.

We plan to conduct theoretical studies to evaluate the deformation state of the bottom of the drill string through the process of formation of slit-like window in well casing.

#### References

1. **Gasnov A.P.** Reconstruction of killed wells: Guide / A.P. Gasnov. - M.: Nedra, 1983. - 128 p.

2. **Guseynov F.A.** Increase of efficiency of kickoff and sidetracking in exploitation wells / F.A.Guseynov, A.M. Rasulov, T.M. Gasanov [etc.]. // Background information. Drilling. - M.: VNIOENG, 1985. - Ed. 12. - 47 p.
3. **Fedorychev V.A.** Methods and technology of drilling of additional bores from well casing / V.A. Fedorychev // Background information. Drilling. - M.: VNIOENG, 1985. - Ed.5. – 51p.
4. **Fedorychev V.A.** Cutting and deflecting machines for drilling of bores from well casing / B. V.A. Fedorychev, O.S. Ivanov, A.D. Kashyna // RNTS Drilling. - 1973. - № 1. - pp. 11-15.
5. **Mirsalaev S.B.** Methods and technology of sidetracking / S.B. Mirsalaev. - M.: Nedra, 1967. - 63 p.
6. **Shenberger V.M.** Methods and technology of construction of sidetracks in oil and gas wells / V.M. Shenberger, G.P.Zozulya, M.G.Geikhman. - Tyumen: TyumSSTU, 2006. - 573 p.
7. **Krylov V.N.** Design of additional deviated and horizontal sidetrack from producing casing of inactive well / V.N. Krylov, A.S.Oganov. - M.: Oil and Gas, 2002. - 102 p.
8. **Amirov A.D.** Well full repair / A.D. Amirov, S.T. Ovtamanov, A.S. Yashyn. - M.: Nedra, 1975. - 326 p. **Drilling** of inclined and horizontal holes / A.G. Kalinin, B.A. Nikitin K.M. Solodky, B.Z. Sultanov. - M.: Nedra, 1997. - 650 p.
9. **Voronenko V.P.** About reserves of efficiency increase of kickoff and sidetracking / V.P. Voronenko// Azerbaijan Oil Industry. - 1978. - № 7. - pp. 60-64.
10. **Ligotsky M.V.** Selection of criteria for design of constructions of sidetrack / M.V. Ligotsky // Oil and gas Industry. - 1997. - № 5. - pp. 18-19.
11. **Gasanov A.P.** Reconstructino of wells / A.P. Gasanov. - M.: Nedra, 1983. - 168 p.
12. **Aliev Sh.N.** Window opening for sidetracking in deep wells / Sh.N. Aliev, N.A.Mananov, V.M. Osipov // Azerbaijan Oil Industry. - 1974. - № 2. - pp. 32-34.
13. **Gulizade M.P.** Law of deviation of inclined wells and criteria of stabilization of inclination / M.P. Gulizade, L.Ya. Sushon // Oil Industry. - 1972. - № 3. - pp. 1-4.

#### Author of article



#### ***Voevidko Igor Volodymyrovych***

*Professor of the Department of Habitability of Ivano-Frankivsk National Technical University of Oil and Gas, Doctor of Engineering Science. He graduated from the Ivano-Frankivsk National Technical University of Oil and Gas. Scientific interests – drilling of oil and gas wells, development of theory and technical means for increase of accuracy of directional wells.*

#### International Scientific Gas Conference

*International Gas Union plans to hold the International Gas*

*Union Research Conference (IGURC 2014) on September 17-19, 2014 in Copenhagen (Denmark).*

*The conference 'Gas Innovations Inspiring Clean Energy' will host*

*over three hundred reports at plenary and section sessions. The plenary sessions will discuss such issues as:*

*Influence of innovations on gas market;*

*Business conditions for scientific research works and industry development;*

*The most important factors for technologies change; and*

*Current news from the world of gas technologies.*

The Agenda includes the issues of gas use, its transport and distribution, gas production, environment protection, security, communications, markets, supply, strategies, etc.

The reports abstracts should be sent until January 6, 2014, participants' registration starts on November 1, 2013;

See detailed information at web-site ***www.igrc2014.com***